

# Authorised Distributors:-

ASH & ALAIN INDIA PVT LTD

S-100, F.I.E.E., Okhla Industrial Area, Phase-ii, New Delhi-110020(India)

Tel : 011-43797575 Fax : 011-43797574 E-mail : sales@ashalain.com

## Temperature Indicator

# K3HB-H

CSM\_K3HB-H\_DS\_E\_5\_1

### New High-speed, High-precision Temperature Indicator

- Capable of high-speed sampling at 50 times per second (20 ms).
- High-resolution of 0.01°C with platinum-resistance thermometer Pt100 input. Thermocouple sensor inputs also support a resolution of 0.1°C for all ranges.
- Temperature input shift is easily set using two points.

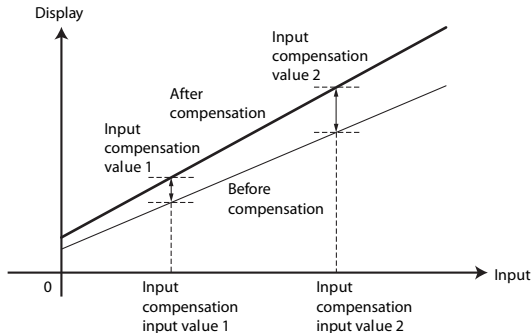

- Series expanded to include DeviceNet models.
- UL certification approval (Certification Mark License).
- CE Marking conformance by third party assessment body.
- Water-resistant enclosure conforms to NEMA 4X (equivalent to IP66).

 Refer to Safety Precautions for All Digital Panel Meters.

## Model Number Structure

### Model Number Legend

Base Units and Optional Boards can be ordered individually or as sets.

#### Base Units

K3HB-H

1            5

#### 1. Input Sensor Code

TA: Temperature input  
Thermocouple input/Platinum-resistance thermometer input

#### 5. Supply Voltage

100-240 VAC: 100 to 240 VAC  
24 VAC/VDC: 24 VAC/VDC

#### Optional Boards

##### Sensor Power Supply/Output Boards

K33-

2

##### Relay/Transistor Output Boards

K34-

3

##### Event Input Boards

K35-

4

Note: 1. CPA can be combined with relay outputs only.

2. Only one of the following can be used by each Digital Indicator: RS-232C/RS-485 communications, a linear output, or DeviceNet communications.

#### Accessories (Sold Separately)

K32-DICN: Special Cable (for event inputs, with 8-pin connector)  
K32-BCD: Special BCD Output Cable

#### Base Units with Optional Boards

K3HB-H

1    2    3    4    5

#### 2. Sensor Power Supply/Output Type Code

- None: None
- CPA: Relay output (PASS: SPDT) + Sensor power supply (12 VDC +/- 10%, 80 mA) (See note 1.)
- L1A: Linear current output (0 to 20 or 4 to 20 mA DC) + Sensor power supply (12 VDC +/- 10%, 80 mA) (See note 2.)
- L2A: Linear voltage output (0 to 5, 1 to 5, or 0 to 10 VDC) + Sensor power supply (12 VDC +/- 10%, 80 mA) (See note 2.)
- A: Sensor power supply (12 VDC +/- 10%, 80 mA)
- FLK1A: Communications (RS-232C) + Sensor power supply (12 VDC +/- 10%, 80 mA) (See note 2.)
- FLK3A: Communications (RS-485) + Sensor power supply (12 VDC +/- 10%, 80 mA) (See note 2.)

#### 3. Relay/Transistor Output Type Code

- None: None
- C1: Relay contact (H/L: SPDT each)
- C2: Relay contact (HH/H/LL/L: SPST-NO each)
- T1: Transistor (NPN open collector: HH/H/PASS/L/LL)
- T2: Transistor (PNP open collector: HH/H/PASS/L/LL)
- BCD \*: BCD output + transistor output (NPN open collector: HH/H/PASS/L/LL)
- DRT: DeviceNet (See note 2.)

\* A Special BCD Output Cable (sold separately) is required.

#### 4. Event Input Type Code

- None: None
- 1: 5 inputs (M3 terminal blocks), NPN open collector
- 2: 8 inputs (10-pin MIL connector), NPN open collector
- 3: 5 inputs (M3 terminal blocks), PNP open collector
- 4: 8 inputs (10-pin MIL connector), PNP open collector

#### Rubber Packing

| Model  |
|--------|
| K32-P1 |

Note: Rubber packing is provided with the Controller.

# Specifications

## ■ Ratings

|  |   |   |
|--|---|---|
| <b>Power supply voltage</b>                  |   | 100 to 240 VAC (50/60 Hz), 24 VAC/VDC, DeviceNet power supply: 24 VDC   |
| <b>Allowable power supply voltage range</b>  |   | 85% to 110% of the rated power supply voltage, DeviceNet power supply: 11 to 25 VDC   |
| <b>Power consumption (See note 1.)</b>       |   | 100 to 240 V: 18 VA max. (max. load)<br>24 VAC/DC: 11 VA/7 W max. (max. load)   |
| <b>Current consumption</b>                   |   | DeviceNet power supply: 50 mA max. (24 VDC)   |
| <b>Input</b>                                 |   | Platinum-resistance thermometer: Pt100<br>Thermocouple: K, J, T, E, L, U, N, R, S, B, W   |
| <b>A/D conversion method</b>                 |   | Delta-Sigma method  |
| <b>External power supply</b>                 |   | See Sensor Power Supply/Output Type Codes   |
| <b>Event inputs (See note 2.)</b>            | <b>Timing input</b>                     | NPN open collector or no-voltage contact signal<br>ON residual voltage: 3 V max.<br>ON current at 0 Ω: 17 mA max.<br>Max. applied voltage: 30 VDC max.<br>OFF leakage current: 1.5 mA max.  |
|  | <b>Startup compensation timer input</b> | NPN open collector or no-voltage contact signal<br>ON residual voltage: 2 V max.<br>ON current at 0 Ω: 4 mA max.  |
|  | <b>Hold input</b>                       | Max. applied voltage: 30 VDC max.   |
|  | <b>Reset input</b>                      | OFF leakage current: 0.1 mA max.  |
|  | <b>Bank input</b>                       |   |
| <b>Output ratings (depends on the model)</b> | <b>Relay output</b>                     | 250 VAC, 30 VDC, 5 A (resistive load)<br>Mechanical life expectancy: 5,000,000 operations, Electrical life expectancy: 100,000 operations   |
|  | <b>Transistor output</b>                | Maximum load voltage: 24 VDC, Maximum load current: 50 mA, Leakage current: 100 μA max.   |
|  | <b>Linear output</b>                    | Linear output 0 to 20 mA DC, 4 to 20 mA DC:<br>Load: 500 Ω max, Resolution: Approx. 10,000, Output error: ±0.5% FS<br>Linear output 0 to 5 VDC, 1 to 5 VDC, 0 to 10 VDC:<br>Load: 5 kΩ max, Resolution: Approx. 10,000, Output error: ±0.5% FS<br>(1 V or less: ±0.15 V; not output for 0 V or less)        |
| <b>Display method</b>                        |   | Negative LCD (backlit LED) display<br>7-segment digital display (Character height: PV: 14.2 mm (green/red); SV: 4.9 mm (green))   |
| <b>Main functions</b>                        |   | Temperature input shift, measurement operation selection, averaging, previous average value comparison, zero-limit, output hysteresis, output OFF delay, output test, display value selection, display color selection, key protection, bank selection, display refresh period, maximum/minimum hold, reset |
| <b>Ambient operating temperature</b>         |   | -10 to 55°C (with no icing or condensation)   |
| <b>Ambient operating humidity</b>            |   | 25% to 85%  |
| <b>Storage temperature</b>                   |   | -25 to 65°C (with no icing or condensation)   |
| <b>Altitude</b>                              |   | 2,000 m max.  |
| <b>Accessories</b>                           |   | Watertight packing, 2 fixtures, terminal cover, unit stickers, instruction manual. DeviceNet models also include a DeviceNet connector (Hirose HR31-5.08P-5SC(01)) and crimp terminals (Hirose HR31-SC-121) (See note 3.)   |

- Note:**
1. DC power supply models require a control power supply capacity of approximately 1 A per Unit when power is turned ON. Particular attention is required when using two or more DC power supply models. The OMRON S8VS-series DC Power Supply Unit is recommended.
  2. PNP input types are also available.
  3. For K3HB-series DeviceNet models, use only the DeviceNet Connector included with the product. The crimp terminals provided are for Thin Cables.

## ■ Characteristics

|   |   |   |
|---|---|---|
| <b>Display range</b>                    | -19,999 to 99,999   |   |
| <b>Accuracy</b>                         | Thermocouple input: ( $\pm 0.3\%$ PV or $\pm 1^\circ\text{C}$ , whichever is larger) $\pm 1$ digit max. (See note.)<br>Platinum resistance thermometer input: ( $\pm 0.2\%$ PV or $\pm 0.8^\circ\text{C}$ , whichever is larger) $\pm 1$ digit max.   |   |
| <b>Sampling period</b>                  | 20 ms (50 times/second)   |   |
| <b>Comparative output response time</b> | Platinum-resistance thermometer input range: 120 ms max.<br>Thermocouple input range: 180 ms max.<br>(The time until the comparative output is output when there is a forced sudden change in the input signal from 15% to 95% or 95% to 15%.)  |   |
| <b>Linear output response time</b>      | Platinum-resistance thermometer input range: 170 ms max.<br>Thermocouple input range: 230 ms max.<br>(The time until the final analog output is reached when there is a forced sudden change in the output signal from 15% to 95% or 95% to 15%.)   |   |
| <b>Insulation resistance</b>            | 20 M $\Omega$ min. (at 500 VDC)   |   |
| <b>Dielectric strength</b>              | 2,300 VAC for 1 min between external terminals and case   |   |
| <b>Noise immunity</b>                   | 100 to 240 VAC models:<br>$\pm 1,500$ V at power supply terminals in normal or common mode<br>(waveform with 1-ns rising edge and pulse width of 1 $\mu\text{s}/100$ ns)<br>24 VAC/VDC models:<br>$\pm 1,500$ V at power supply terminals in normal or common mode<br>(waveform with 1-ns rising edge and pulse width of 1 $\mu\text{s}/100$ ns)  |   |
| <b>Vibration resistance</b>             | Frequency: 10 to 55 Hz; Acceleration: 50 m/s <sup>2</sup> , 10 sweeps of 5 min each in X, Y, and Z directions   |   |
| <b>Shock resistance</b>                 | 150 m/s <sup>2</sup> (100 m/s <sup>2</sup> for relay outputs) 3 times each in 3 axes, 6 directions  |   |
| <b>Weight</b>                           | Approx. 300 g (Base Unit only)  |   |
| <b>Degree of protection</b>             | <b>Front panel</b>  | Conforms to NEMA 4X for indoor use (equivalent to IP66) |
|   | <b>Rear case</b>  | IP20  |
|   | <b>Terminals</b>  | IP00 + finger protection (VDE0106/100)                  |
| <b>Memory protection</b>                | EEPROM (non-volatile memory)<br>Number of rewrites: 100,000   |   |
| <b>Applicable standards</b>             | UL61010C-1, CSA C22.2 No. 1010.1 (evaluated by UL)<br>EN61010-1 (IEC61010-1): Pollution degree 2/Overvoltage category II<br>EN61326: 1997, A1: 1998, A2: 2001   |   |
| <b>EMC</b>                              | EMI: EN61326 industrial applications<br>Electromagnetic radiation interference<br>CISPR 11 Group 1, Class A<br>Terminal interference voltage<br>CISPR 11 Group 1, Class A<br>EMS: EN61326 industrial applications<br>Electrostatic Discharge Immunity<br>EN61000-4-2: 4 kV (contact), 8 kV (in air)<br>Radiated Electromagnetic Field Immunity<br>EN61000-4-3: 10 V/m 1 kHz sine wave amplitude modulation (80 MHz to 1 GHz, 1.4 to 2 GHz)<br>Electrical Fast Transient/Burst Immunity<br>EN61000-4-4: 2 kV (power line), 1 kV (I/O signal line)<br>Surge Immunity<br>EN61000-4-5: 1 kV with line (power line), 2 kV with ground (power line)<br>Conducted Disturbance Immunity<br>EN61000-4-6: 3 V (0.15 to 80 MHz)<br>Power Frequency Magnetic Immunity<br>EN61000-4-8: 30 A/m (50 Hz) continuous time<br>Voltage Dips and Interruptions Immunity<br>EN61000-4-11: 0.5 cycle, 0°/180°, 100% (rated voltage) |   |

**Note:** K, T, N ( $-100^\circ\text{C}$  or less):  $\pm 2^\circ\text{C} \pm 1$  digit max.  
U, L:  $\pm 2^\circ\text{C} \pm 1$  digit max.  
B (400 $^\circ\text{C}$  max.): Nothing specified.  
R, S (200 $^\circ\text{C}$  max.):  $\pm 3^\circ\text{C} \pm 1$  digit max.  
W: ( $\pm 0.3\%$  PV or  $\pm 3^\circ\text{C}$  whichever is larger)  $\pm 1$  digit max.

## Input Ranges

### Platinum-resistance Thermometer/Thermocouple

| Input type                                   | Platinum-resistance thermometer |             | Thermocouple |            |            |            |            |            |            |            |             |             |               |             |             |  |  |  |  |        |  |
|--|---------------------------------|-------------|--------------|------------|------------|------------|------------|------------|------------|------------|-------------|-------------|---------------|-------------|-------------|--|--|--|--|--------|--|
| Name   | Pt100                           |             | K            | J          | T          | E          | L          | U          | N          | R          | S           | B           | W (W/Re 5-26) |             |             |  |  |  |  |        |  |
| Connected terminals                          | E4 - E5 - E6                    |             | E5 - E6      |            |            |            |            |            |            |            |             |             |               |             |             |  |  |  |  |        |  |
| Temperature range (°C)                       | 2300                            |             |              |            |            |            |            |            |            |            |             |             |               |             |             |  |  |  |  | 2300.0 |  |
|  | 1800                            |             |              |            |            |            |            |            |            |            |             |             |               |             |             |  |  |  |  |        |  |
|  | 1300                            |             |              |            |            |            |            |            |            |            |             |             |               |             |             |  |  |  |  |        |  |
|  | 900                             |             |              |            |            |            |            |            |            |            |             |             |               |             |             |  |  |  |  |        |  |
|  | 800                             |             |              |            |            |            |            |            |            |            |             |             |               |             |             |  |  |  |  |        |  |
|  | 700                             |             |              |            |            |            |            |            |            |            |             |             |               |             |             |  |  |  |  |        |  |
|  | 600                             |             |              |            |            |            |            |            |            |            |             |             |               |             |             |  |  |  |  |        |  |
|  | 500                             |             |              |            |            |            |            |            |            |            |             |             |               |             |             |  |  |  |  |        |  |
|  | 400                             |             |              |            |            |            |            |            |            |            |             |             |               |             |             |  |  |  |  |        |  |
|  | 300                             |             |              |            |            |            |            |            |            |            |             |             |               |             |             |  |  |  |  |        |  |
|  | 200                             |             |              |            |            |            |            |            |            |            |             |             |               |             |             |  |  |  |  |        |  |
|  | 100                             |             |              |            |            |            |            |            |            |            |             |             |               |             |             |  |  |  |  |        |  |
|  | 0                               |             |              |            |            |            |            |            |            |            |             |             |               |             |             |  |  |  |  |        |  |
|  | -100                            |             |              |            |            |            |            |            |            |            |             |             |               |             |             |  |  |  |  |        |  |
|  | -200                            |             |              |            |            |            |            |            |            |            |             |             |               |             |             |  |  |  |  |        |  |
|  |                                 |             |              |            |            |            |            |            |            |            |             |             |               |             |             |  |  |  |  |        |  |
| Setting code                                 | <i>0-Pl</i>                     | <i>1-Pl</i> | <i>2-P</i>   | <i>3-P</i> | <i>4-J</i> | <i>5-J</i> | <i>6-E</i> | <i>7-E</i> | <i>8-L</i> | <i>9-U</i> | <i>10-N</i> | <i>11-R</i> | <i>12-S</i>   | <i>13-B</i> | <i>14-W</i> |  |  |  |  |        |  |
| Minimum setting unit (comparative set value) | 0.1°C                           | 0.01°C      | 0.1°C        |            |            |            |            |            |            |            |             |             |               |             |             |  |  |  |  |        |  |

The range shown in dark shading indicates the factory setting.

### Celsius/Fahrenheit Correlation Values and Setting/Specified Ranges

| Input type | Setting range     |                   | Indication range  |                   |
|------------|-------------------|-------------------|-------------------|-------------------|
|            | °C                | °F                | °C                | °F                |
| Pt100 (1)  | -200.0 to 850.0   | -300.0 to 1500.0  | -305.0 to 955.0   | -480.0 to 1680.0  |
| Pt100 (2)  | -150.00 to 150.00 | -199.99 to 300.00 | -180.00 to 180.00 | -199.99 to 350.00 |
| K (1)      | -200.0 to 1300.0  | -300.0 to 2300.0  | -350.0 to 1450.0  | -560.0 to 2560.0  |
| K (2)      | -20.0 to 500.0    | 0.0 to 900.0      | -72.0 to 552.0    | -90.0 to 990.0    |
| J (1)      | -100.0 to 850.0   | -100.0 to 1500.0  | -195.0 to 945.0   | -260.0 to 1660.0  |
| J (2)      | -20.0 to 400.0    | 0.0 to 750.0      | -62.0 to 442.0    | -75.0 to 825.0    |
| T          | -200.0 to 400.0   | -300.0 to 700.0   | -260.0 to 460.0   | -400.0 to 800.0   |
| E          | 0.0 to 600.0      | 0.0 to 1100.0     | -60.0 to 660.0    | -110.0 to 1210.0  |
| L          | -100.0 to 850.0   | -100.0 to 1500.0  | -195.0 to 945.0   | -260.0 to 1660.0  |
| U          | -200.0 to 400.0   | -300.0 to 700.0   | -260.0 to 460.0   | -400.0 to 800.0   |
| N          | -200.0 to 1300.0  | -300.0 to 2300.0  | -350.0 to 1450.0  | -560.0 to 2560.0  |
| R          | 0.0 to 1700.0     | 0.0 to 3000.0     | -170.0 to 1870.0  | -300.0 to 3300.0  |
| S          | 0.0 to 1700.0     | 0.0 to 3000.0     | -170.0 to 1870.0  | -300.0 to 3300.0  |
| B          | 100.0 to 1800.0   | 300.0 to 3200.0   | -70.0 to 1970.0   | 10.0 to 3490.0    |
| W          | 0.0 to 2300.0     | 0.0 to 4100.0     | -230.0 to 2530.0  | -410.0 to 4510.0  |

## Common Specifications

### ■ Event Input Ratings

| Input type | S-TMR, HOLD, RESET, ZERO, BANK1, BANK2, BANK4  | TIMING  |
|------------|--|---|
| Contact    | ON: 1 kΩ max., OFF: 100 kΩ min.  | ---   |
| No-contact | ON residual voltage: 2 V max.<br>OFF leakage current: 0.1 mA max.<br>Load current: 4 mA max.<br>Maximum applied voltage: 30 VDC max. | ON residual voltage: 3 V max.<br>OFF leakage current: 1.5 mA max.<br>Load current: 17 mA max.<br>Maximum applied voltage: 30 VDC max. |

### ■ Output Ratings

#### Contact Output

| Item                       | Resistive loads<br>(250 VAC, cosφ=1;<br>30 VDC, L/R=0 ms) | Inductive loads<br>(250 VAC, closed<br>circuit, cosφ=0.4;<br>30 VDC, L/R=7 ms) |
|----------------------------|---|--|
| Rated load                 | 5 A at 250 VAC<br>5 A at 30 VDC                           | 1 A at 250 VAC<br>1 A at 30 VDC  |
| Mechanical life expectancy | 5,000,000 operations                                      |  |
| Electrical life expectancy | 100,000 operations  |  |

#### Transistor Output

|                      |             |
|----------------------|-------------|
| Maximum load voltage | 24 VDC      |
| Maximum load current | 50 mA       |
| Leakage current      | 100 μA max. |

#### Linear Output

| Item                     | 0 to 20 mA     | 4 to 20 mA | 0 to 5 V   | 1 to 5 V | 0 to 10 V |
|--------------------------|----------------|------------|--|----------|-----------|
| Allowable load impedance | 500 Ω max.     |            | 5 kΩ min.  |          |           |
| Resolution               | Approx. 10,000 |            |  |          |           |
| Output error             | ±0.5%FS        |            | ±0.5%FS (1 V or less: ±0.15 V; not output for 0 V or less) |          |           |

#### Serial Communications Output

| Item                   | RS-232C, RS-485              |
|------------------------|------------------------------|
| Communications method  | Half duplex                  |
| Synchronization method | Start-stop synchronization   |
| Baud rate              | 9,600, 19,200, or 38,400 bps |
| Transmission code      | ASCII                        |
| Data length            | 7 bits or 8 bits             |
| Stop bit length        | 2 bits or 1 bit              |
| Error detection        | Vertical parity and FCS      |
| Parity check           | Odd, even                    |

**Note:** For details on serial and DeviceNet communications, refer to the *Digital Indicator K3HB Communications User's Manual* (Cat.No. N129).

#### BCD Output I/O Ratings (Input Signal Logic: Negative)

| I/O signal name |   | Item                               | Rating                   |            |
|-----------------|---|------------------------------------|--------------------------|------------|
| Inputs          | REQUEST<br>HOLD<br>MAX<br>MIN<br>RESET        | Input signal                       | No-voltage contact input |            |
|                 |   | Input current for no-voltage input | 10 mA                    |            |
|                 |   | Signal level                       | ON voltage               | 1.5 V max. |
|                 |   |                                    | OFF voltage              | 3 V min.   |
| Outputs         | DATA<br>POLARITY<br>OVER<br>DATA VALID<br>RUN | Maximum load voltage               | 24 VDC                   |            |
|                 |   | Maximum load current               | 10 mA                    |            |
|                 |   | Leakage current                    | 100 μA max.              |            |
|                 | HH<br>H<br>PASS<br>L<br>LL                    | Maximum load voltage               | 24 VDC                   |            |
|                 |   | Maximum load current               | 50 mA                    |            |
|                 |   | Leakage current                    | 100 μA max.              |            |

**Note:** For details on serial and DeviceNet communications, refer to the *Digital Indicator K3HB Communications User's Manual* (Cat.No. N129).

## DeviceNet Communications

| <b>Communications protocol</b>             |                                  | Conforms to DeviceNet  |                               |                       |                         |                               |          |               |     |      |          |               |     |      |          |               |     |       |
|--|----------------------------------|--|-------------------------------|-----------------------|-------------------------|-------------------------------|----------|---------------|-----|------|----------|---------------|-----|------|----------|---------------|-----|-------|
| <b>Supported communications</b>            | <b>Remote I/O communications</b> | Master-Slave connection (polling, bit-strobe, COS, cyclic)<br>Conforms to DeviceNet communications standards.  |                               |                       |                         |                               |          |               |     |      |          |               |     |      |          |               |     |       |
|  | <b>I/O allocations</b>           | Allocate any I/O data using the Configurator.<br>Allocate any data, such as DeviceNet-specific parameters and variable area for Digital Indicators.<br>Input area: 2 blocks, 60 words max.<br>Output area: 1 block, 29 words max.<br>(The first word in the area is always allocated for the Output Execution Enabled Flags.)  |                               |                       |                         |                               |          |               |     |      |          |               |     |      |          |               |     |       |
|  | <b>Message communications</b>    | Explicit message communications<br>CompoWay/F communications commands can be executed (using explicit message communications)  |                               |                       |                         |                               |          |               |     |      |          |               |     |      |          |               |     |       |
| <b>Connection methods</b>                  |                                  | Combination of multi-drop and T-branch connections (for trunk and drop lines)  |                               |                       |                         |                               |          |               |     |      |          |               |     |      |          |               |     |       |
| <b>Baud rate</b>                           |                                  | DeviceNet: 500, 250, or 125 Kbps (automatic follow-up)   |                               |                       |                         |                               |          |               |     |      |          |               |     |      |          |               |     |       |
| <b>Communications media</b>                |                                  | Special 5-wire cable (2 signal lines, 2 power supply lines, 1 shield line)   |                               |                       |                         |                               |          |               |     |      |          |               |     |      |          |               |     |       |
| <b>Communications distance</b>             |                                  | <table border="1"> <thead> <tr> <th>Baud rate</th> <th>Network length (max.)</th> <th>Drop line length (max.)</th> <th>Total drop line length (max.)</th> </tr> </thead> <tbody> <tr> <td>500 Kbps</td> <td>100 m (100 m)</td> <td>6 m</td> <td>39 m</td> </tr> <tr> <td>250 Kbps</td> <td>100 m (250 m)</td> <td>6 m</td> <td>78 m</td> </tr> <tr> <td>125 Kbps</td> <td>100 m (500 m)</td> <td>6 m</td> <td>156 m</td> </tr> </tbody> </table> <p>The values in parentheses are for Thick Cable.</p> | Baud rate                     | Network length (max.) | Drop line length (max.) | Total drop line length (max.) | 500 Kbps | 100 m (100 m) | 6 m | 39 m | 250 Kbps | 100 m (250 m) | 6 m | 78 m | 125 Kbps | 100 m (500 m) | 6 m | 156 m |
| Baud rate                                  | Network length (max.)            | Drop line length (max.)  | Total drop line length (max.) |                       |                         |                               |          |               |     |      |          |               |     |      |          |               |     |       |
| 500 Kbps                                   | 100 m (100 m)                    | 6 m  | 39 m                          |                       |                         |                               |          |               |     |      |          |               |     |      |          |               |     |       |
| 250 Kbps                                   | 100 m (250 m)                    | 6 m  | 78 m                          |                       |                         |                               |          |               |     |      |          |               |     |      |          |               |     |       |
| 125 Kbps                                   | 100 m (500 m)                    | 6 m  | 156 m                         |                       |                         |                               |          |               |     |      |          |               |     |      |          |               |     |       |
| <b>Communications power supply</b>         |                                  | 24-VDC DeviceNet power supply  |                               |                       |                         |                               |          |               |     |      |          |               |     |      |          |               |     |       |
| <b>Allowable voltage fluctuation range</b> |                                  | 11 to 25-VDC DeviceNet power supply  |                               |                       |                         |                               |          |               |     |      |          |               |     |      |          |               |     |       |
| <b>Current consumption</b>                 |                                  | 50 mA max. (24 VDC)  |                               |                       |                         |                               |          |               |     |      |          |               |     |      |          |               |     |       |
| <b>Maximum number of nodes</b>             |                                  | 64 (DeviceNet Configurator is counted as one node when connected)  |                               |                       |                         |                               |          |               |     |      |          |               |     |      |          |               |     |       |
| <b>Maximum number of slaves</b>            |                                  | 63   |                               |                       |                         |                               |          |               |     |      |          |               |     |      |          |               |     |       |
| <b>Error control checks</b>                |                                  | CRC errors   |                               |                       |                         |                               |          |               |     |      |          |               |     |      |          |               |     |       |
| <b>DeviceNet power supply</b>              |                                  | Supplied from DeviceNet communications connector   |                               |                       |                         |                               |          |               |     |      |          |               |     |      |          |               |     |       |

## Internal Block Diagram

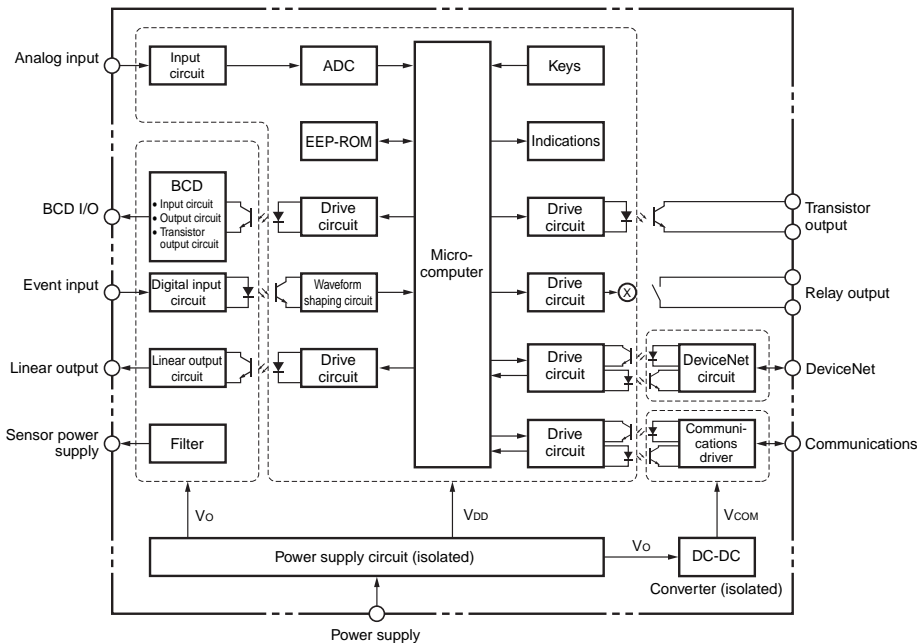

## Power Supply Derating Curve for Sensor (Reference Value)

With 12 V

With 10 V

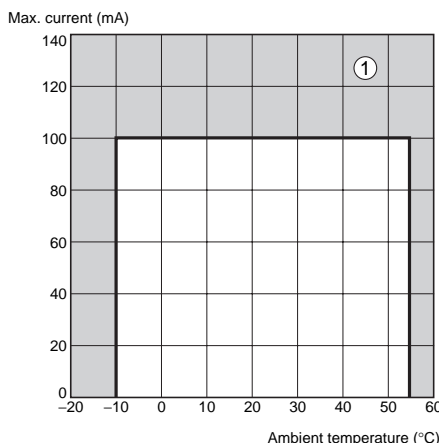
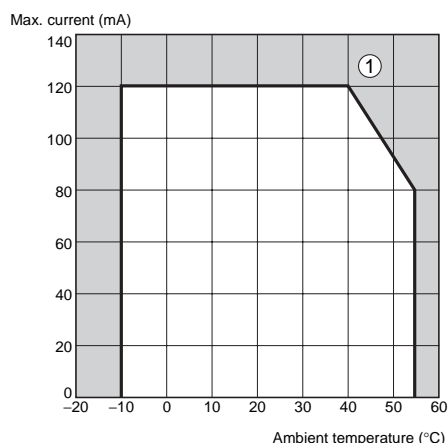

- Note:** 1. The above values are for standard mounting. The derating curve differs depending on the mounting conditions.  
 2. Do not use the Sensor outside of the derating area (i.e., do not use it in the area labeled ① in the above graphics). Doing so may occasionally cause deterioration or damage to internal components.

## Component Names and Functions

### Max/Min status indicator

Turns ON when the maximum value or minimum value is displayed in the RUN level.

### Level/bank display

In RUN level, displays the bank if the bank function is ON. (Turns OFF if the bank function is OFF.)  
 In other levels, displays the current level.

### Comparative output status indicators

Display the status of comparative outputs.

### Status indicators

| Display | Function                                   |
|---------|--|
| Hold    | Turns ON/OFF when hold input turns ON/OFF. |

### PV display

Displays PVs, maximum values, minimum values, parameter names, and error names.

### Position meter

Displays the position of the PV with respect to a desired scale.

### SV display

Displays SV and monitor values.

### SV display status indicators

| Display      | Function  |
|--------------|---|
| TG           | Turns ON when the timing signal turns ON. Otherwise OFF.                              |
| HH, H, L, LL | In RUN level, turn ON when the comparative set values HH, H, L, and LL are displayed. |

### MAX/MIN Key

Used to switch the display between the PV, maximum value, and minimum value and to reset the maximum and minimum values.

### LEVEL Key

Used to switch level.

### MODE Key

Used to switch the parameters displayed.

### SHIFT Key

Used to change parameter settings. When changing a set value, this key is used to move along the digits.

### UP Key

When changing a set value, this key is used to change the actual value.



## BCD Output Timing Chart

A REQUEST signal from a Programmable Controller or other external device is required to read BCD data.

### Single Sampling Data Output

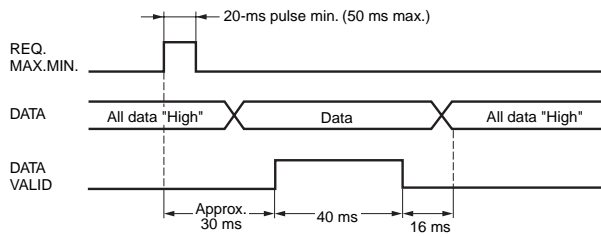

The data is set in approximately 30 ms from the rising edge of the REQUEST signal and the DATA VALID signal is output. When reading the data from a Programmable Controller, start reading the data when the DATA VALID signal turns ON. The DATA VALID signal will turn OFF 40 ms later, and the data will turn OFF 16 ms after that.

### Continuous Data Output

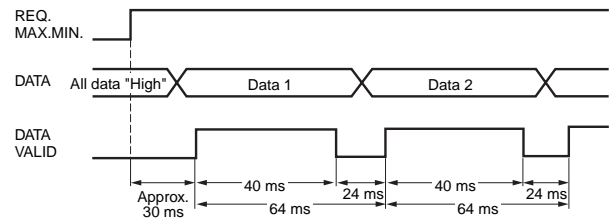

Measurement data is output every 64 ms while the REQUEST signal remains ON.

**Note:** If HOLD is executed when switching between data 1 and data 2, either data 1 or data 2 is output depending on the timing of the hold signal. The data will not go LOW.

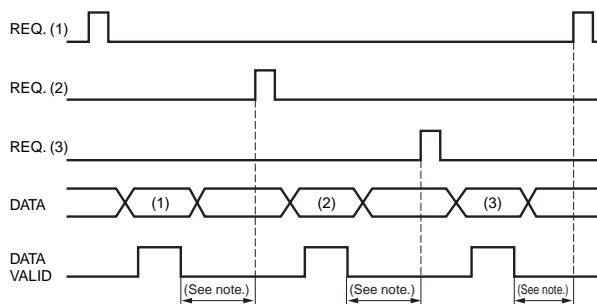
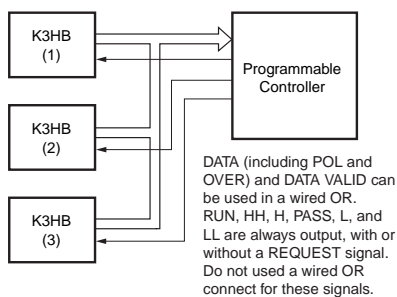

**Note:** Leave 20 ms min. between DATA VALID turning OFF and the REQUEST signal.

### Programmable Controller Connection Example

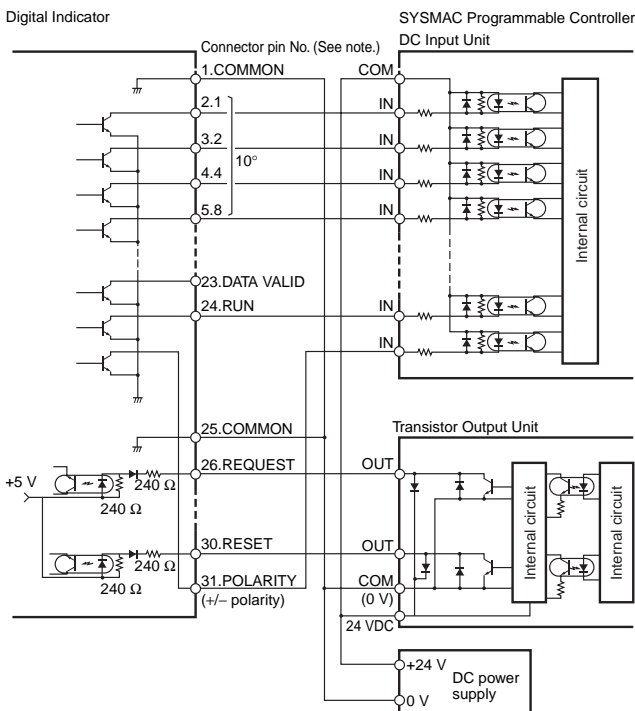

### Display Unit Connection Example

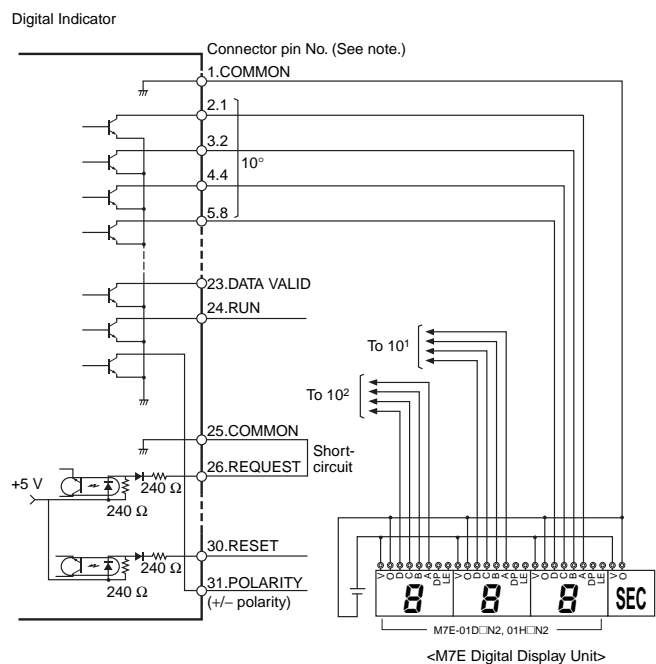

**Note:** The BCD output connector pin number is the D-sub connector pin number when the BCD Output Cable (sold separately) is connected. This number differs from the pin number for the Digital Indicator narrow pitch connector (manufactured by Honda Tsushin Kogyo Co., Ltd.).

Refer to the following User's Manual for application precautions and other information required when using the Digital Indicator:  
*K3HB-S/-X/-V/-H Digital Indicator User's Manual (Cat. No. N128)*  
 The manual can be downloaded from the following site in PDF format: OMRON Industrial Web <http://www.fa.omron.co.jp>





# Connections

## Terminal Arrangement

**Note:** Insulation is used between signal input, event input, output, and power supply terminals.

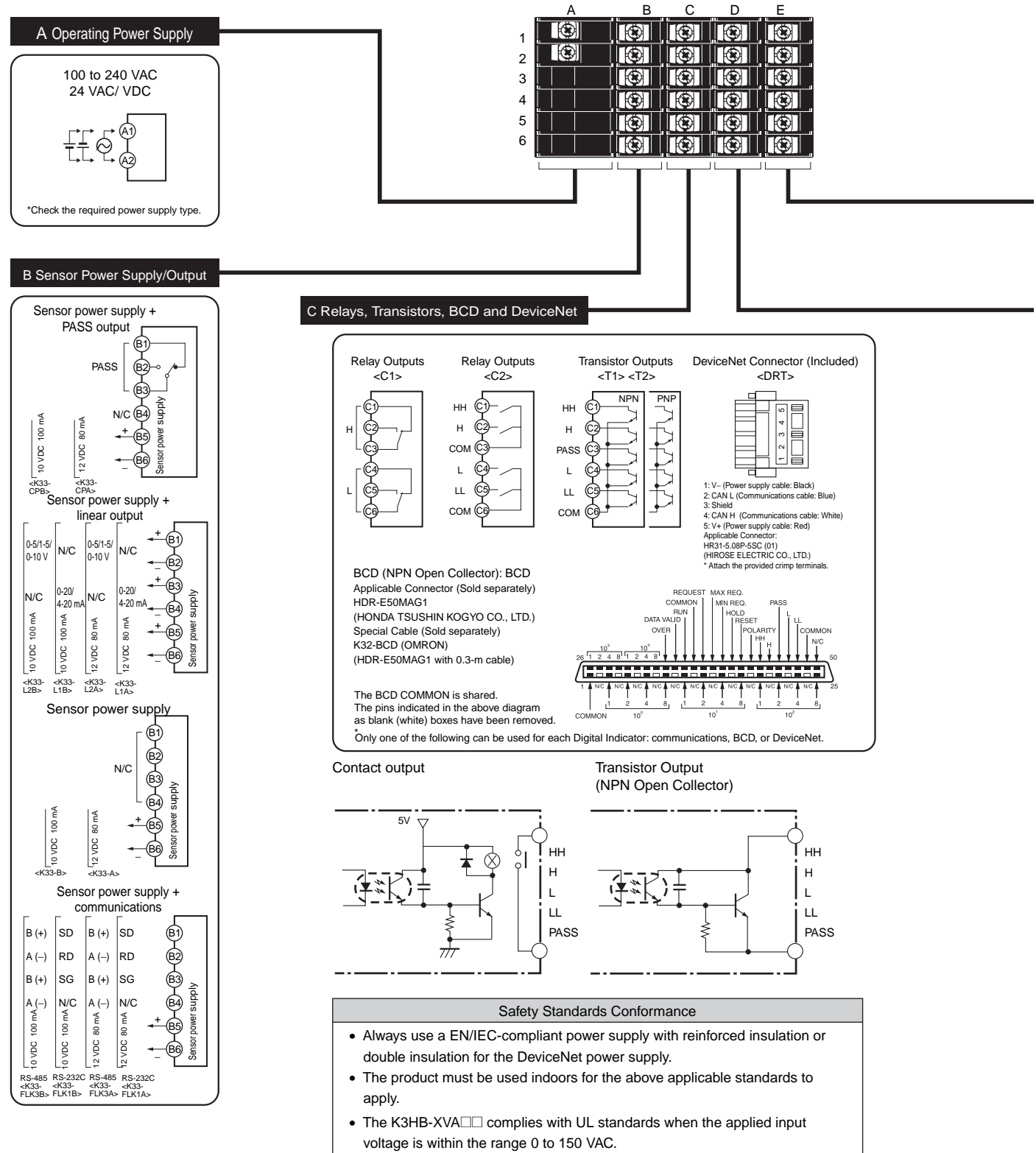

## E Analog Input

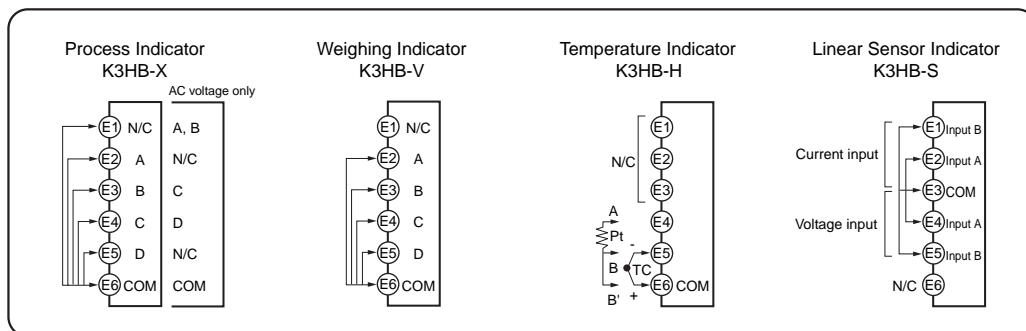

## D Event Input

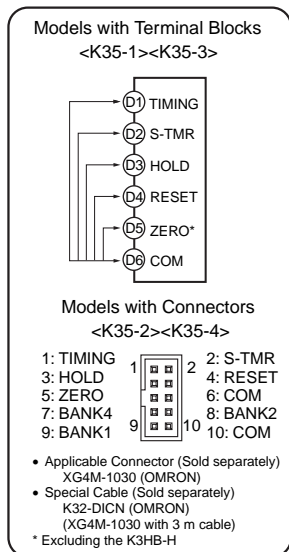

- Use terminal pin D6 as the common terminal.
- Use NPN open collector or no-voltage contacts for event input. PNP types are also available.

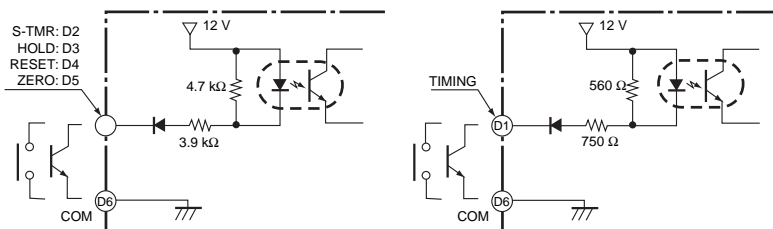

## BCD Output Cable

| Model   | Shape   | Pin arrangement   |
|---------|---|---|
| K32-BCD | <p>K3HB end</p> <p>38 mm</p> <p>300 mm</p> <p>46.5 mm</p> <p>Connected device end (PLC, display device, etc.)</p> <p>Cover: HDR-E50LPA5 (manufactured by Honda Tsushin Co., Ltd.)<br/>Connector: HDR-E50MAG1 (manufactured by Honda Tsushin Co., Ltd.)</p> <p>D-sub connector (37-pin female)<br/>Cover: 17JE-37H-1A (manufactured by DDK)<br/>Connector: Equivalent to 17JE-13370-02 (manufactured by DDK)<br/>Stand: 17L-002A (manufactured by DDK)</p> | <p>COMMON</p> <p>10<sup>0</sup> 1 2 3 4 5 6 7 8 9 10 11 12 13 14 15 16 17 18 19 20 21 22 23 24 25 26 27 28 29 30 31 32 33 34 35 36 37</p> <p>4 10<sup>4</sup></p> <p>OVER<br/>DATA VALID<br/>RUN<br/>COMMON<br/>REQUEST<br/>MAX REQ.<br/>MIN REQ.<br/>HOLD<br/>RESET<br/>POLARITY<br/>HH<br/>H<br/>PASS<br/>L<br/>LL<br/>COMMON</p> |

**Note:** The BCD Output Cable has a D-sub plug. Cover: 17JE-37H-1A (manufactured by DDK); Connector: equivalent to 17JE-23370-02 (D1) (manufactured by DDK)

## Special Cable (for Event Inputs with 8-pin Connector)

| Model    | Appearance  | Wiring   |         |             |   |     |   |       |   |      |   |       |   |     |   |     |   |       |   |       |   |       |    |     |
|----------|---|--|---------|-------------|---|-----|---|-------|---|------|---|-------|---|-----|---|-----|---|-------|---|-------|---|-------|----|-----|
| K32-DICN | <p>9 10</p> <p>1 2</p> <p>3,000 mm</p> <p>Cable marking (3 m)</p> | <table border="1"> <thead> <tr> <th>Pin No.</th> <th>Signal name</th> </tr> </thead> <tbody> <tr><td>1</td><td>N/C</td></tr> <tr><td>2</td><td>S-TMR</td></tr> <tr><td>3</td><td>HOLD</td></tr> <tr><td>4</td><td>RESET</td></tr> <tr><td>5</td><td>N/C</td></tr> <tr><td>6</td><td>COM</td></tr> <tr><td>7</td><td>BANK4</td></tr> <tr><td>8</td><td>BANK2</td></tr> <tr><td>9</td><td>BANK1</td></tr> <tr><td>10</td><td>COM</td></tr> </tbody> </table> | Pin No. | Signal name | 1 | N/C | 2 | S-TMR | 3 | HOLD | 4 | RESET | 5 | N/C | 6 | COM | 7 | BANK4 | 8 | BANK2 | 9 | BANK1 | 10 | COM |
| Pin No.  | Signal name   |  |         |             |   |     |   |       |   |      |   |       |   |     |   |     |   |       |   |       |   |       |    |     |
| 1        | N/C   |  |         |             |   |     |   |       |   |      |   |       |   |     |   |     |   |       |   |       |   |       |    |     |
| 2        | S-TMR   |  |         |             |   |     |   |       |   |      |   |       |   |     |   |     |   |       |   |       |   |       |    |     |
| 3        | HOLD  |  |         |             |   |     |   |       |   |      |   |       |   |     |   |     |   |       |   |       |   |       |    |     |
| 4        | RESET   |  |         |             |   |     |   |       |   |      |   |       |   |     |   |     |   |       |   |       |   |       |    |     |
| 5        | N/C   |  |         |             |   |     |   |       |   |      |   |       |   |     |   |     |   |       |   |       |   |       |    |     |
| 6        | COM   |  |         |             |   |     |   |       |   |      |   |       |   |     |   |     |   |       |   |       |   |       |    |     |
| 7        | BANK4   |  |         |             |   |     |   |       |   |      |   |       |   |     |   |     |   |       |   |       |   |       |    |     |
| 8        | BANK2   |  |         |             |   |     |   |       |   |      |   |       |   |     |   |     |   |       |   |       |   |       |    |     |
| 9        | BANK1   |  |         |             |   |     |   |       |   |      |   |       |   |     |   |     |   |       |   |       |   |       |    |     |
| 10       | COM   |  |         |             |   |     |   |       |   |      |   |       |   |     |   |     |   |       |   |       |   |       |    |     |

## ■ Main Functions

### Measurement

#### Timing Hold

##### Normal

- Continuously performs measurement and always outputs based on comparative results.

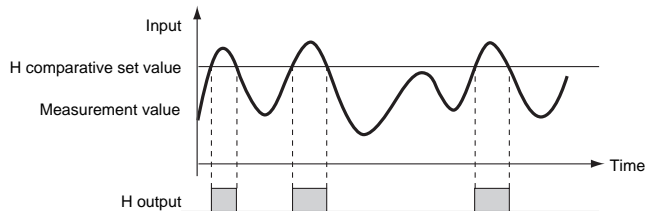

##### Peak Hold/Bottom Hold

- Measures the maximum (or minimum) value in a specified period.

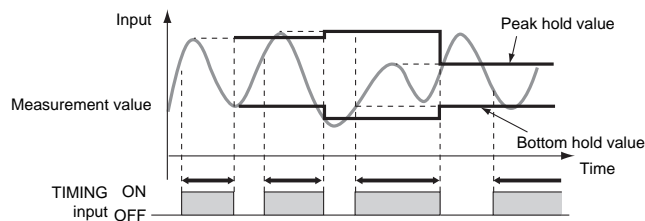

##### Sampling Hold

- Holds the measurement at the rising edge of the TIMING signal.

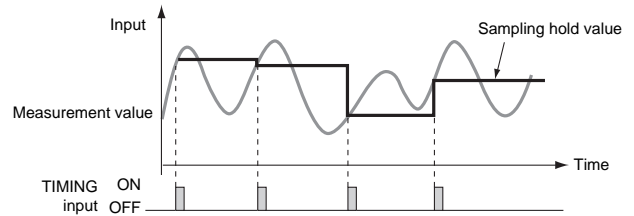

##### Peak-to-peak Hold

- Measures the difference between the maximum and minimum values in a specified period.

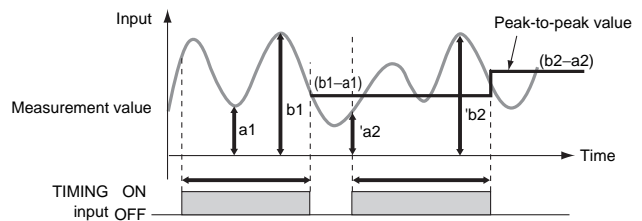

#### Standby Sequence

Turns the comparative output OFF until the measurement value enters the PASS range.

#### Average Processing

Average processing of input signals with extreme changes or noise smooths out the display and makes control stable.

#### Previous Average Value Comparison

Slight changes can be removed from input signals to detect only extreme changes.

#### Temperature Input Shift

Shifts the temperature input value.

## Input Compensation/Display

### Zero-trimming

Compensates for mild fluctuations in input signals due to factors such as sensor temperature drift, based on OK (PASS) data at measurement. (This function can be used with sampling hold, peak hold, or bottom hold.)

### Zero-limit

Changes the display value to 0 for input values less than the set value. It is enabled in normal mode only. (This function can be used, for example, to stop negative values being displayed or to eliminate flickering and minor inconsistencies near 0.)

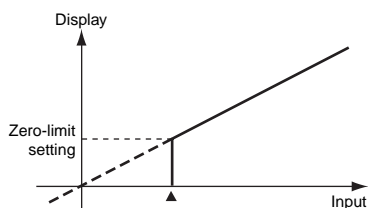

### Display Refresh Period

The display refresh period can be lengthened to reduce flickering and thereby make the display easier to read.

### Display Color Selection

Values can be displayed in either red or green. With comparative output models, the display color can also be set to change according to the status of comparative outputs (e.g., green to red or red to green).

Example) Setting: *Green*

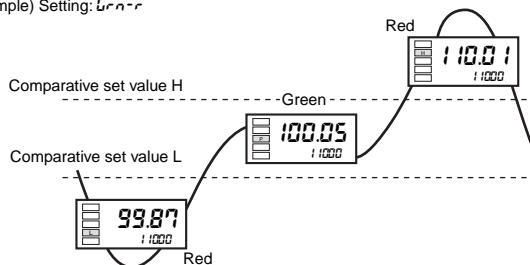

### Display Value Selection

The current display value can be selected from the present value, the maximum value, and the minimum value.

### Step Value

It is possible to specify (i.e., restrict) the values that the smallest displayed digit can change by. For example, if the setting is 2, the smallest digit will only take the values 0, 2, 4, 6, or 8 and if the setting is 5, it will only take the values 0 or 5. If the setting is 10, it will only take the value of 0.

### Interruption Memory

- The minimum and maximum values when the power supply is turned OFF can be saved if interruption memory is turned ON.
- If interruption memory is ON, the maximum and minimum values after the last resetting will be displayed.
- If interruption memory is OFF, the maximum and minimum values will be displayed after the power supply is turned ON (or after the reset input is performed).

## Output

### Comparative Output Pattern

The output pattern for comparative outputs can be selected. In addition to high/low comparison with set values, output based on level changes is also possible. (Use the type of output pattern appropriate for the application.)

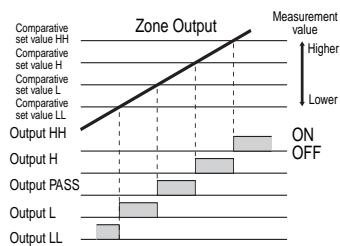
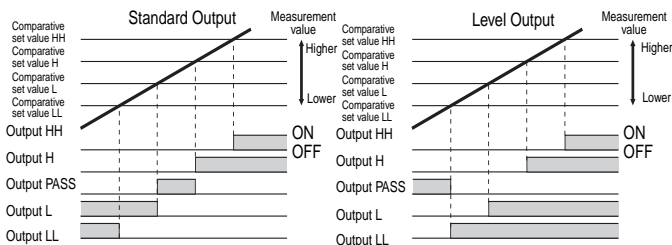

### Output Logic

Reverses the output operation of comparative outputs for comparative results.

### Hysteresis

Prevents comparative output chattering when the measurement value fluctuates slightly near the set value.

Example: Comparative Output Pattern (Standard Output)

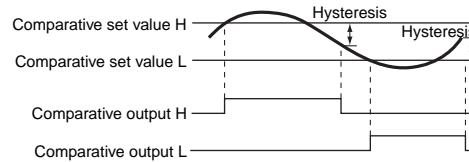

### Startup Compensation Timer

Measurement can be stopped for a set time using external input.

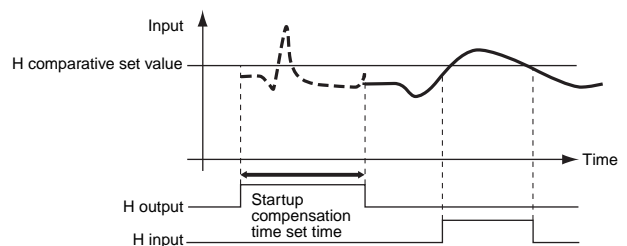

### PASS Output Change

Comparative results other than PASS and error signals can be output from the PASS output terminal.

## Dimensions

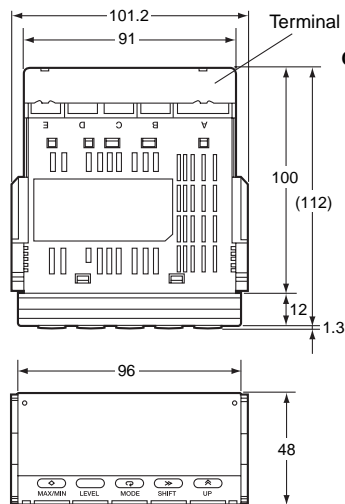

### Character Size for Main Display (mm)

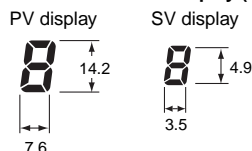

### Panel Cutout Dimensions

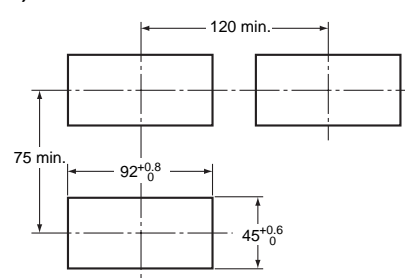

\*DeviceNet models: 97 mm  
Terminal: M3, Terminal Cover: Accessory

## ■ Wiring Precautions

- For terminal blocks, use the crimp terminals suitable for M3 screws.
- Tighten the terminal screws to the recommended tightening torque of approx. 0.5 N·m.
- To prevent inductive noise, separate the wiring for signal lines from that for power lines.

## Wiring

- Use the crimp terminals suitable for M3 screws shown below.

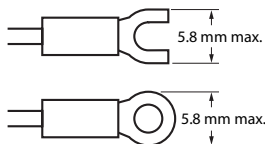

## Unit Stickers

- Select the appropriate units from the unit sticker sheets provided and attach the sticker to the Indicator.

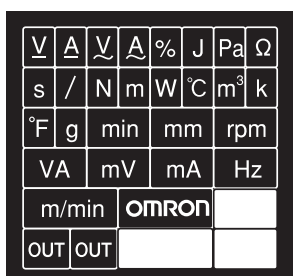

Note: When using for meters, such as weighing meters, use the units specified by regulations on weights and measures.

## ■ Mounting Method

1. Insert the K3HB into the mounting cutout in the panel.
2. Insert watertight packing around the Unit to make the mounting watertight.

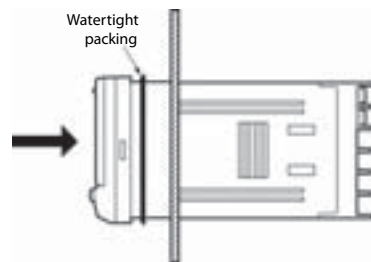

3. Insert the adapter into the grooves on the left and right sides of the rear case and push until it reaches the panel and is fixed in place.

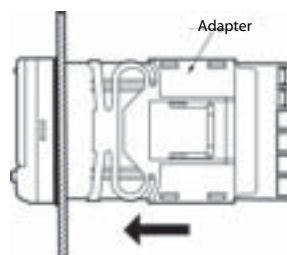

## ■ LCD Field of Vision

The K3HB is designed to have the best visibility at the angles shown in the following diagram.

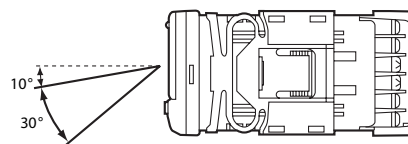

## ■ Rubber Packing (Sold Separately)

K32-P1

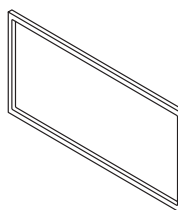

If the rubber packing is lost or damaged, it can be ordered using the following model number: K32-P1.

(Depending on the operating environment, deterioration, contraction, or hardening of the rubber packing may occur and so, in order to ensure the level of waterproofing specified in NEMA4, periodic replacement is recommended.)

Note: Rubber packing is provided with the Controller.

ALL DIMENSIONS SHOWN ARE IN MILLIMETERS.

To convert millimeters into inches, multiply by 0.03937. To convert grams into ounces, multiply by 0.03527.

In the interest of product improvement, specifications are subject to change without notice.



Authorised Distributors:-

ASH & ALAIN INDIA PVT LTD

S-100, F.I.E.E., Okhla Industrial Area, Phase-ii, New Delhi-110020(India)

Tel : 011-43797575 Fax : 011-43797574 E-mail : sales@ashalain.com